

# Torque Wrench Calibrator

- accurate
- easy-to-use
- fast operation
- economical solution
- modular system
- compact and portable
- rugged and reliable

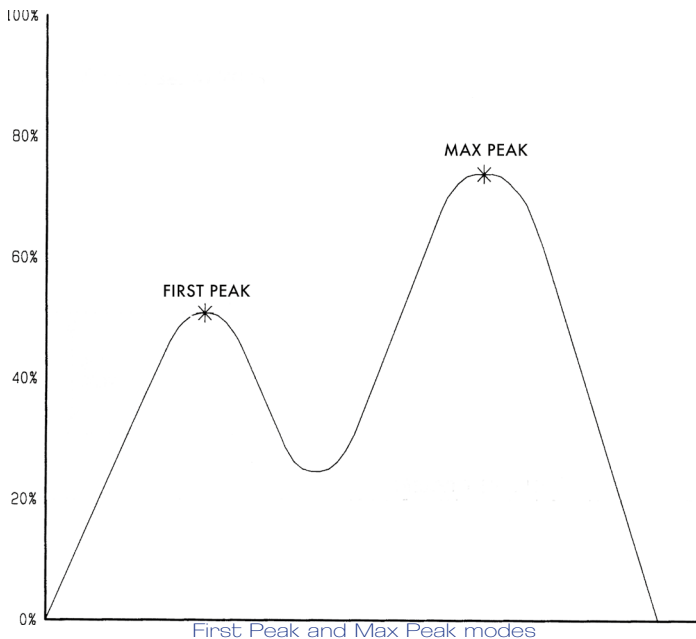

TWC shown testing a mechanical torque wrench



accurate  
portable  
easy-to-use

The Mecmesin Torque Wrench Calibrator (TWC) is a versatile, easy-to-use system, which can verify the torque applied by any type of 'click action', 'break back' or dial indicator torque wrench with ease. Based on the AFTI universal force and torque display and designed as a modular system, the TWC is the ultimate in flexibility. The standard system is supplied with its own dedicated transducer connected to the AFTI, but for added flexibility a range of different "smart" transducers are available to allow testing up to 1000 N.m.

Three operating modes cover all common testing requirements. 'Normal' mode shows the live value, 'First Peak' mode records the true 'click torque' and 'Max' mode records the highest value. The TWC is easily reset using the push button torque zeroing facility.

Battery-powered, the TWC is a portable instrument ideal for use in calibration laboratories and production lines. It also has an inbuilt RS232 interface to download data to a printer or PC for further statistical analysis.

# Mecmesin

testing to perfection

## Dimensions mm (inch)

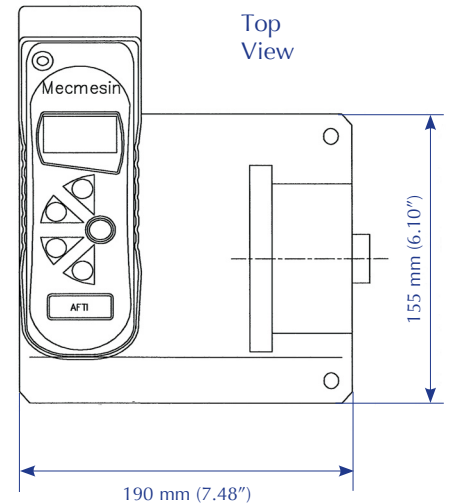
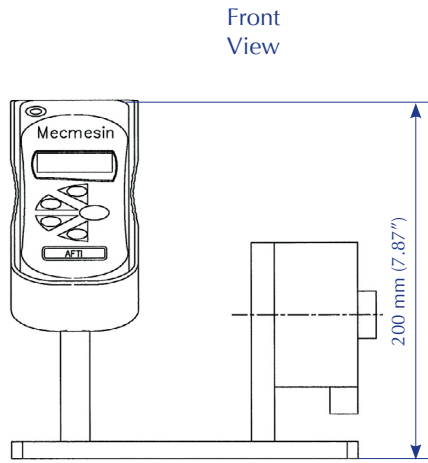
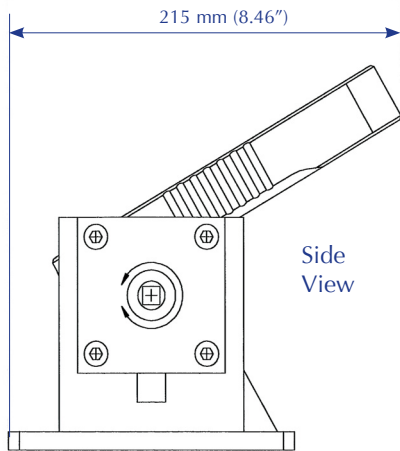

## Specifications

Model	Rated Torque Range (F.S.D)	Resolution					
		N-m	kg-m	kg-cm	lb-ft	lb-in	SQ. drive
TWC 1	15 N-m/11 lb-ft	15 x 0.003	1.5 x 0.0003	150 x 0.03	11 x 0.003	130 x 0.03	3/8"
TWC 2	60 N-m/44 lb-ft	60 x 0.02	6 x 0.002	600 x 0.2	44 x 0.009	520 x 0.2	3/8"
TWC 3	100 N-m/72 lb-ft	100 x 0.02	10 x 0.002	1000 x 0.2	72 x 0.02	870 x 0.2	1/2"
TWC 4	150 N-m/110 lb-ft	150 x 0.03	15 x 0.003	1500 x 0.3	110 x 0.03	1300 x 0.3	1/2"
TWC 5	600 N-m/440 lb-ft	600 x 0.2	60 x 0.02	6000 x 2.0	440 x 0.09	-	3/4"
TWC 6	1000 N-m/720 lb-ft	1000 x 0.2	100 x 0.02	10000 x 2.0	720 x 0.2	-	1"

**Standard Accuracy:** ± 0.5% of full scale

### AFTI Specifications

Operating Temperature: 20°C ± 2°C  
 Output:  
 RS232-C: 8 data bits, 1 Start bit, 1 Stop bit, no parity  
 Digimatic  
 Analogue

DISTRIBUTOR STAMP



FS 58553

003

Mecmesin reserves the right to alter equipment specifications without prior notice.

E&OE

**Head Office - UK**  
Mecmesin Limited

w: [www.mecmesin.com](http://www.mecmesin.com)  
e: [sales@mecmesin.com](mailto:sales@mecmesin.com)

**France**  
Mecmesin France

w: [www.mecmesin.fr](http://www.mecmesin.fr)  
e: [contact@mecmesin.fr](mailto:contact@mecmesin.fr)

**Germany**  
Mecmesin GmbH

w: [www.mecmesin.de](http://www.mecmesin.de)  
e: [info@mecmesin.de](mailto:info@mecmesin.de)

**North America**  
Mecmesin Corporation

w: [www.mecmesincorp.com](http://www.mecmesincorp.com)  
e: [info@mecmesincorp.com](mailto:info@mecmesincorp.com)

**Asia**  
Mecmesin Asia Co., Ltd

w: [www.mecmesinasia.com](http://www.mecmesinasia.com)  
e: [sales@mecmesinasia.com](mailto:sales@mecmesinasia.com)

**China**  
Mecmesin (Shanghai) Pte Ltd

w: [www.mecmesin.cn](http://www.mecmesin.cn)  
e: [sales@mecmesin.cn](mailto:sales@mecmesin.cn)